

**SUBMITTAL DRAWING**

JOB NAME: \_\_\_\_\_  
 LOCATION: \_\_\_\_\_  
 ARCHITECT: \_\_\_\_\_  
 ENGINEER: \_\_\_\_\_  
 CONTRACTOR: \_\_\_\_\_

**ALL-FUEL CHIMNEY  
 SUPPORT BRACKET  
 ASSEMBLY**

DATE: 05/04/05

SUBMITTED BY: \_\_\_\_\_

DRAWING #: D1-17

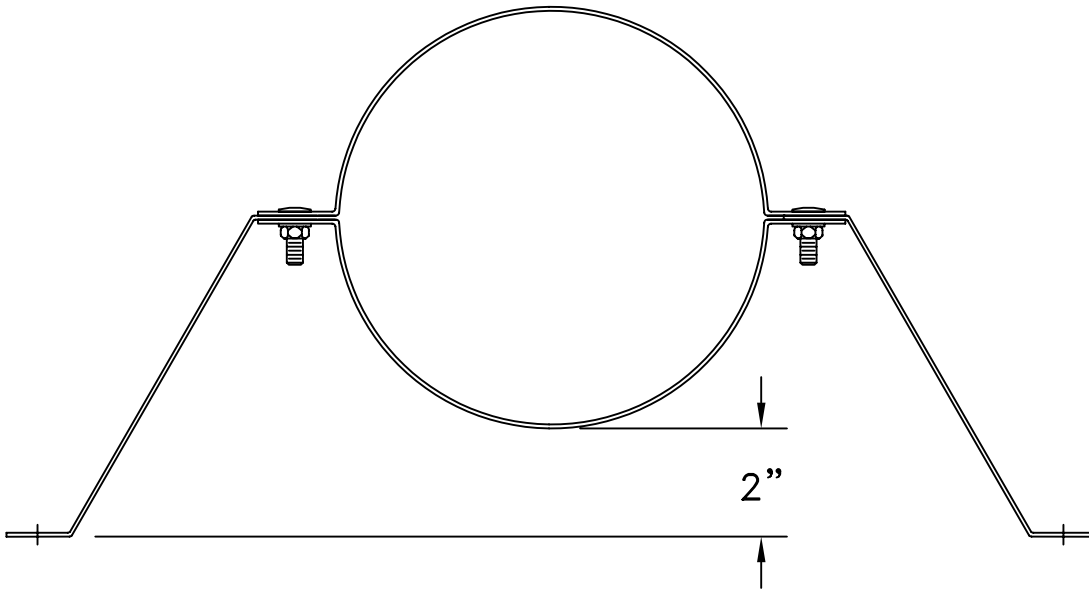

PART NO.

6HS-SBA

8HS-SBA

10FB-SBA



• MATERIAL: 0.058 GALV.